

**UNIGRAPHICS**

---

***MILL MANUFACTURING PROCESS  
WORKBOOK***

***September 2002***

***MT11040 – Unigraphics NX***

**EDS Inc.**

# Proprietary & Restricted Rights Notices

---

## Copyright

Proprietary right of Unigraphics Solutions Inc., its subcontractors, or its suppliers are included in this software, in the data, documentation, or firmware related thereto, and in information disclosed therein. Neither this software, regardless of the form in which it exists, nor such data, information, or firmware may be used or disclosed to others for any purpose except as specifically authorized in writing by Unigraphics Solutions Inc. Recipient by accepting this document or utilizing this software agrees that neither this document nor the information disclosed herein nor any part thereof shall be reproduced or transferred to other documents or used or disclosed to others for manufacturing or any other purpose except as specifically authorized in writing by Unigraphics Solutions Inc.

©2002 Electronic Data Systems Corporation. All rights reserved.

## Restricted Rights Legend

The commercial computer software and related documentation are provided with restricted rights. Use, duplication or disclosure by the U.S. Government is subject to the protections and restrictions as set forth in the Unigraphics Solutions Inc. commercial license for the software and/or documentation as prescribed in DOD FAR 227-7202-3(a), or for Civilian Agencies, in FAR 27.404(b)(2)(i), and any successor or similar regulation, as applicable. Unigraphics Solutions Inc., 10824 Hope Street, Cypress, CA 90630.

## Warranties and Liabilities

All warranties and limitations thereof given by Unigraphics Solutions Inc. are set forth in the license agreement under which the software and/or documentation were provided. Nothing contained within or implied by the language of this document shall be considered to be a modification of such warranties.

The information and the software that are the subject of this document are subject to change without notice and should not be considered commitments by Unigraphics Solutions Inc.. Unigraphics Solutions Inc. assumes no responsibility for any errors that may be contained within this document.

The software discussed within this document is furnished under separate license agreement and is subject to use only in accordance with the licensing terms and conditions contained therein.

## Trademarks

**EDS, the EDS logo, UNIGRAPHICS SOLUTIONS®, UNIGRAPHICS®, GRIP®, PARASOLID®, UG®, UG/...®, UG SOLUTIONS®, iMAN®** are trademarks or registered trademarks of Electronic Data Systems Corporation or its subsidiaries. All other logos or trademarks used herein are the property of their respective owners.

## *Mill Manufacturing Process Workbook* Publication History:

Version 16.0	.....	March 1999
Version 17.0	.....	January 2001
Version 17.0	.....	June 2001
Version 18.0	.....	September 2001
Unigraphics NX	.....	September 2002

## The Manufacturing Process

The workbook project consists of various aspects of machining a part of a manufacturing assembly. The manufacturing assembly is comprised of the work holding device which is a vice, blank material, and the cover housing. The cover housing part is considered to be the *Master Model* and the vise and blank material are considered component parts of the assembly.

The cover housing part will be machined in two setups, the 1st setup with the top side in the up position, the 2nd setup with the bottom side in the up position. In this class, we will only machine the 1st setup.

Below is an illustration of the manufacturing assembly that you will use in the 1st setup for tool path generation.

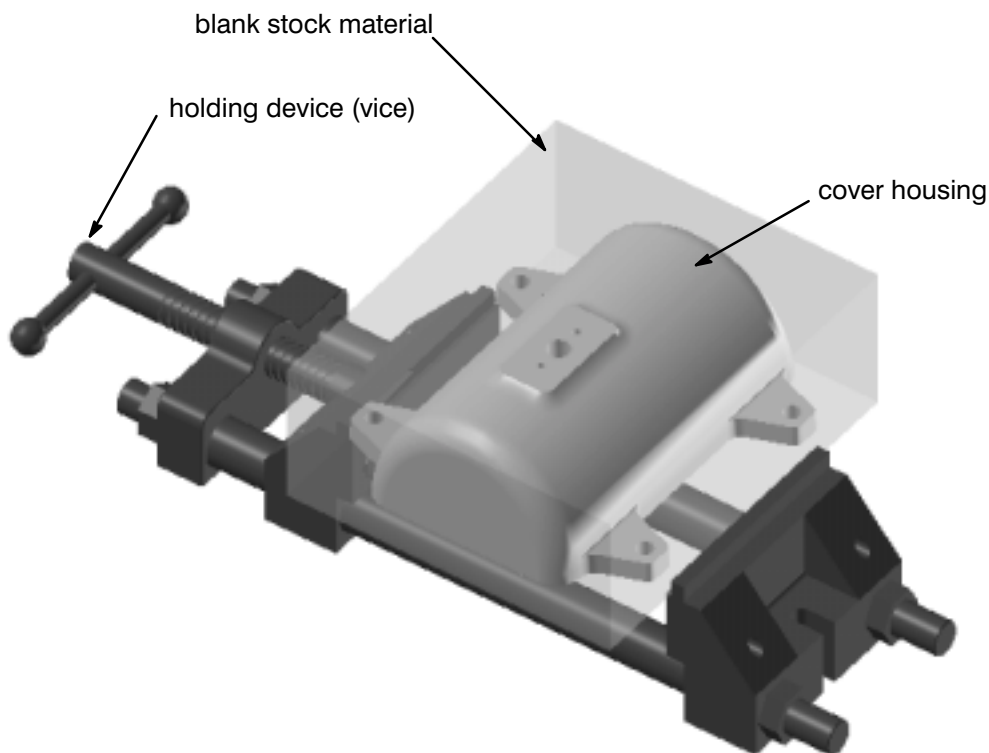

The manufacturing processes or methods that you will use, in this workbook, may or may not be the same approach, in order or content, that you would use at your company. The end result, the final part, is the same. What is more important, in this class, is gaining an understanding of the methodology and application of using the various manufacturing options of UNIGRAPHICS, allowing you to customize tool path generation to methods or processes that you are familiar with.

The following flowchart illustrates the Manufacturing process steps that you will use when creating and processing tool paths in UNIGRAPHICS.

# Unigraphics Manufacturing Process

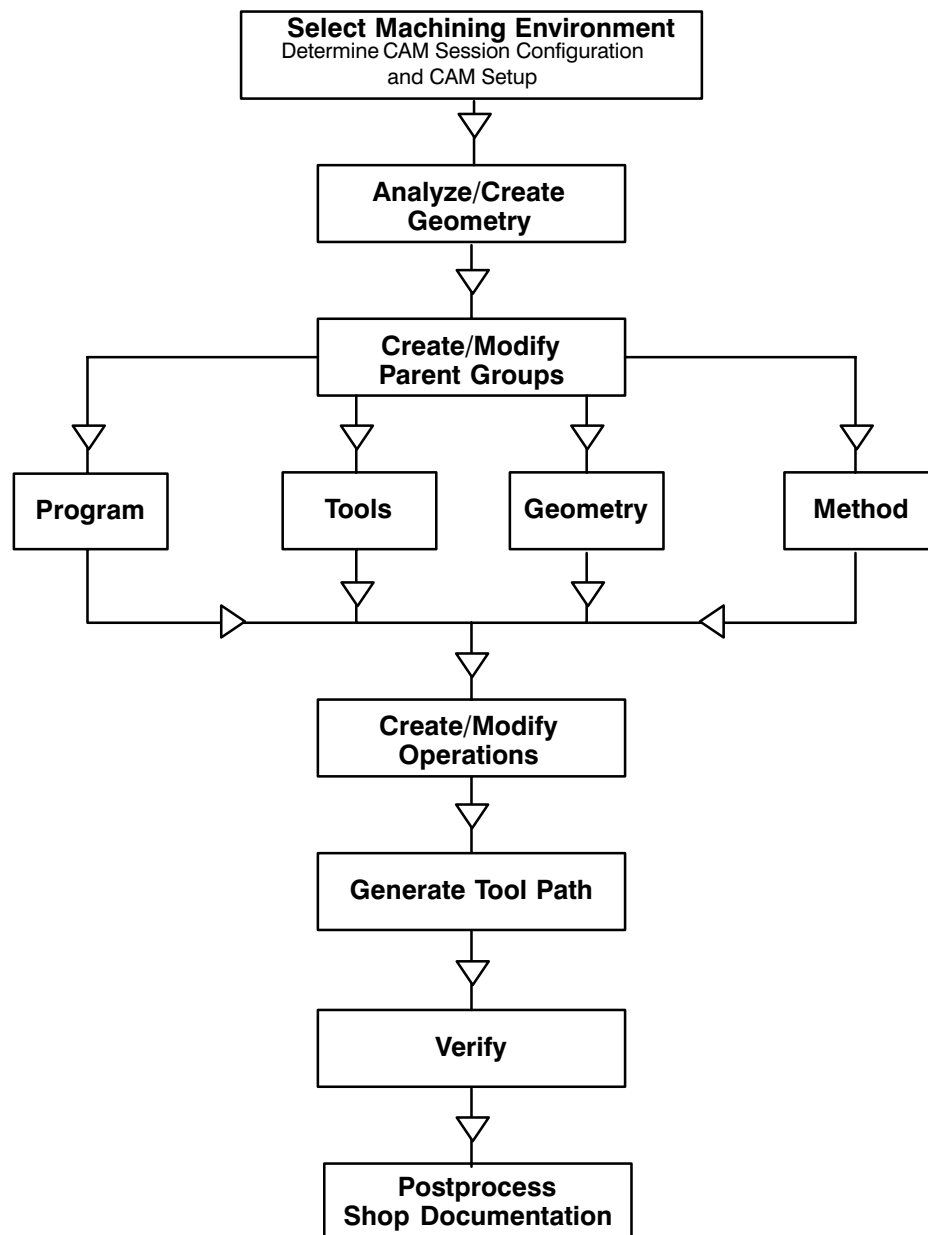

**(This Page Intentionally Left Blank)**

# Process Planning

## Section 1



---

A manufacturing process plan describes the complete step by step procedure of manufacturing a part. Items in such a plan often include the area of manufacturing (department), type of machining (milling, turning, grinding, etc.), description of operations to perform, fixturing of the part, tooling required, and any other information which is necessary for successful manufacturing.

The following process planning sheets represent the manufacturing of the cover housing part. Included are the operation number, work center designation, operation description, operation name, and tool description. A definition of these items follows:

- **Operation Number** is the sequential order in which a process is performed.
- **Work Center** is the particular work area in which the operation is performed.
- **Description** is the detailed description of the operation that is to be performed.
- **Operation Name** is the actual name of the operation used to machine the specific feature or task.
- **Tool** is the description of the tool used to machine the specific feature.

1

Operation Number	Work Center	Description	Operation Name	Tool
		<b>Cover Housing</b>		
<b>100</b>	<b>Inspection</b>	<b>X-ray stock for defects</b>		
<b>200</b>	<b>Manual Machining</b>	<b>Horizontal Mill Mill stock to 11"x169.5"x43.75"</b>		
<b>300</b>		<b>Mount stock in vise.</b>		
<b>400</b>	<b>CNC Machining</b>	<b>3-axis vertical or horizontal machining center, mount vice to machine, top side of part is up.</b>		
400.01		Rough top of cover, cavity mill operation type.	rough_cover	1.250 dia., end mill, 250 cr
400.02		Mill faces, face milling operation type	mill_faces	.750 dia., end mill
400.03		Contour non steep areas.	fc_non_steep	.750 ball mill carbide cutter
400.04		Profile cut steep areas	zlevel_profile_steep	.750x.125 carbide end mill
400.05		Profile flanges—4 places	profile_flanges	.375 dia., end mill
Operation Number	Work Center	Description	Operation Name	Tool



400.06		Spot drill all holes, seven total	spot_drill	spotdrill
400.07		Drill .625 diameter hole, one only.	drill_.625_holes	.625 HSS drill
400.08		drill .46875 diameter holes, 4 places.	drill_.46875	.46875 diameter drill
400.09		drill .207 diameter holes, 2 places	drill_.207	.207 diameter drill
<b>500</b>	<b>Inspection</b>	<b>Inspect 1st article features machined in operation numbers 400.01 thru 400.09</b>		
<b>600</b>	<b>CNC Machining Center</b>	<b>3–Axis Vertical Machining Center. Flip part over in vise, bottom side of cover housing is up.</b>		





**(This Page Intentionally Left Blank)**

# Preparing the Cover Housing for Machining

Section 2

## Unigraphics Manufacturing Process Manufacturing Operation Preparation

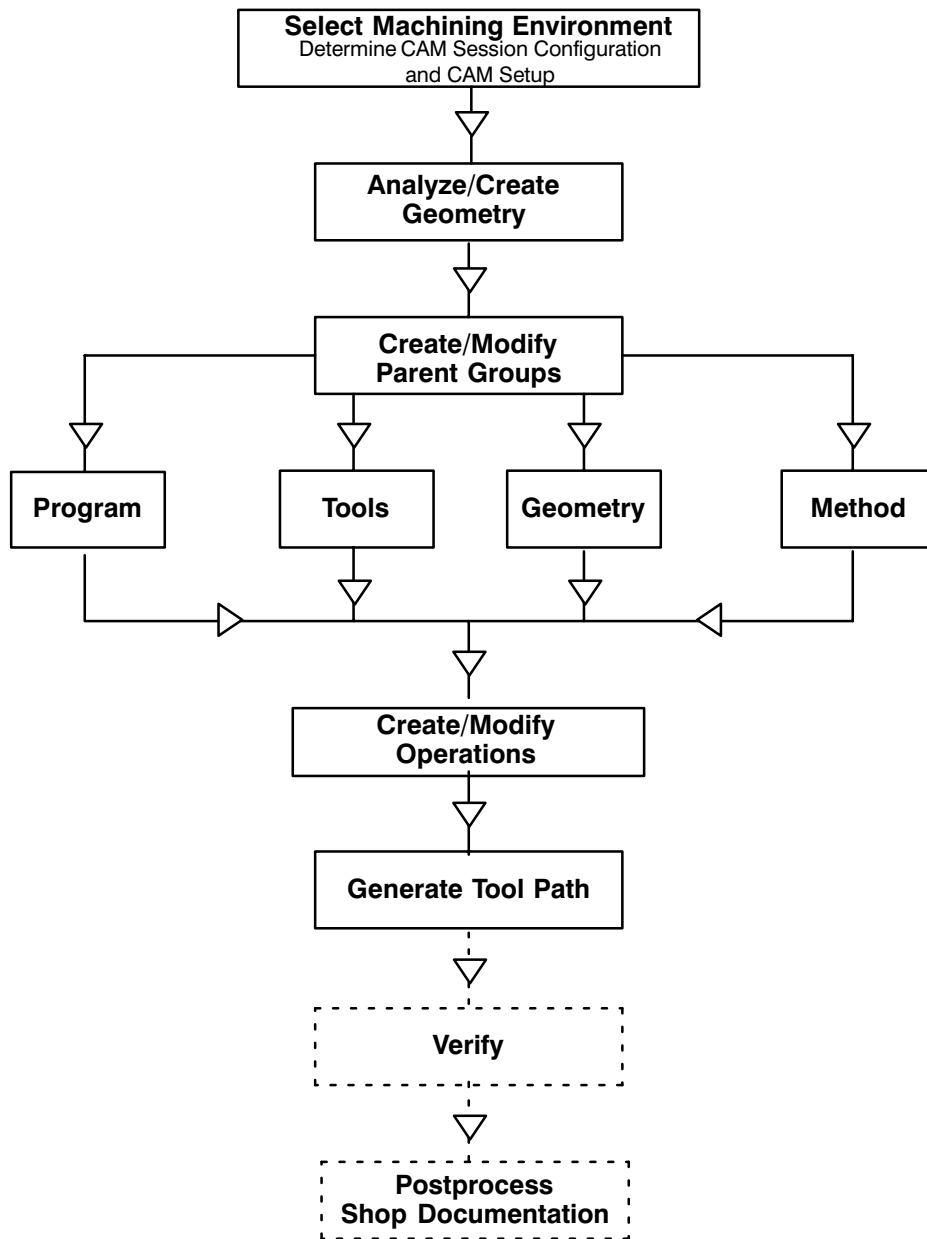

Before you start to create operations and generate tool paths, take some time to become familiar with this project part.

**Step 1** Open the part, `mmp_explode_cover_mfg.prt`, from the `workbook_parts` directory.

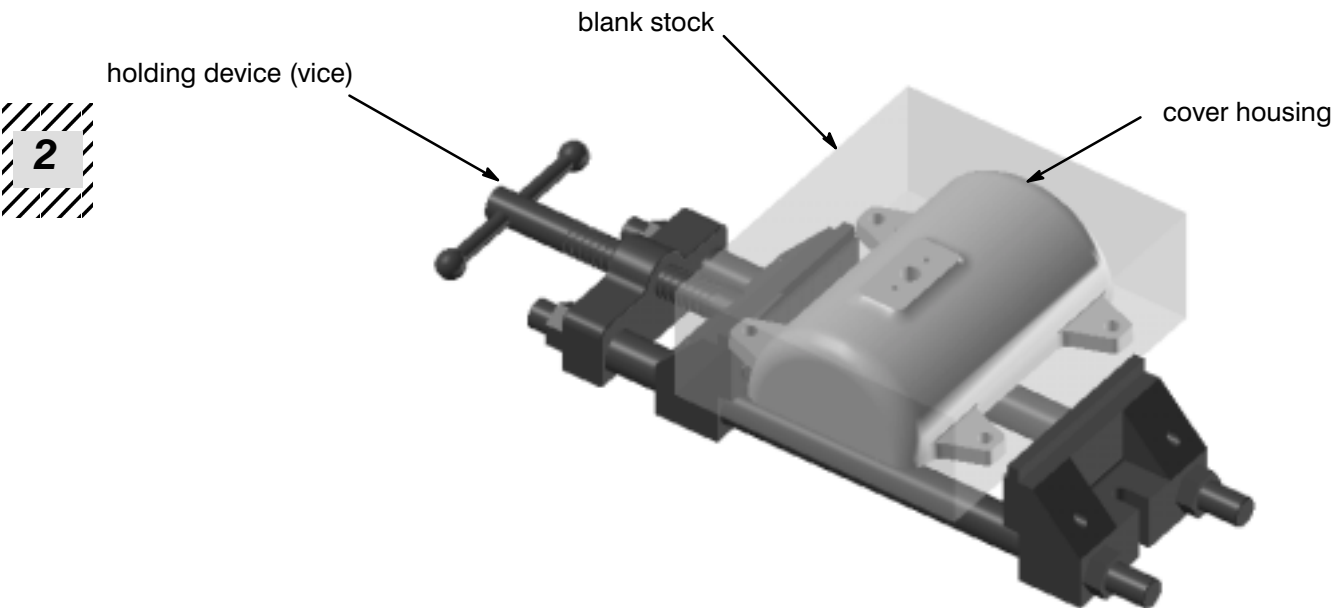

**Step 2** Rename the part `***_explode_cover_mfg.prt` where `***` represents your initials.

**Step 3** Examine the assembly and the various component parts using the Assembly Navigator.

**Step 4** Enter the Manufacturing application.

Notice that there were no previous operations or parent groups, other than defaults.

Before you choose operation types, numerous items must be taken into consideration for achieving the desired output. Items, such as cutting tool types and sizes, must be defined or retrieved from libraries. Feeds and speeds, based on part material and cutter material, must be determined. Geometry must be analyzed as to planar or contoured type and the Machining Environment must be selected and created. Planning the use of geometry in the various operations will aid in the creation and use of geometry parent groups. This will save you numerous steps in the selection of geometry as you machine the part.

The following steps will allow you to create the operations that are needed to successfully create and generate tool paths for the cover housing.

**Step 5** Create the Machining Environment.

Base the Machining Environment on the types of operations that are necessary to machine the part.

**Step 6** Determine the geometry types. Determine planar and contour geometry used for the various operation types.

Analyze the geometry needed to rough and finish the part.

- Are there planar or contour geometry types?
- Are there tapered walls or specific areas that need to be “cleaned-up” with smaller tools?
- Are there the same or different geometry types for rough and finish operations?

Before selecting the operation type, you must identify which geometry can be machined using planar or contouring techniques.



**Step 7** Identify tools per the Process Planning sheet needed for the various operations. Create tools as required. The following list of tools were derived from the Process Planning sheet.

***TOOLING LIST***

**DRILLING TOOLS**

TOOL NAME	DESCRIPTION	DIAMETER	TIP ANG	FLUTE LEN	ADJ REG
SPOT-.5-90-HSS	SPOTDRILLING_TOOL	0.5000	90.0000	1.5000	6
DR-.625-HSS	DRILL	0.6250	135.0000	3.5000	7
DR-.46875	DRILL	0.4688	135.0000	4.0000	8
DR-.207	DRILL	0.2070	135.0000	3.0000	9

**MILLING TOOLS**

TOOL NAME	DESCRIPTION	DIAMETER	COR RAD	FLUTE LEN	ADJ REG
EM-1.25-.25-CARBIDE	MILL	1.2500	0.2500	3.0000	1
EM-.75-0-CARBIDE	MILL	0.7500	0.0000	2.5000	2
BM-.75-CARBIDE	MILL	0.7500	0.3750	2.2500	3
EM-.75-.125-CARBIDE	MILL	0.7500	0.1250	1.5000	4
DM-0.375-5-HSS	MILL	0.3750	0.0000	0.7500	5

The cover housing can be roughed using a Cavity Milling operation type.

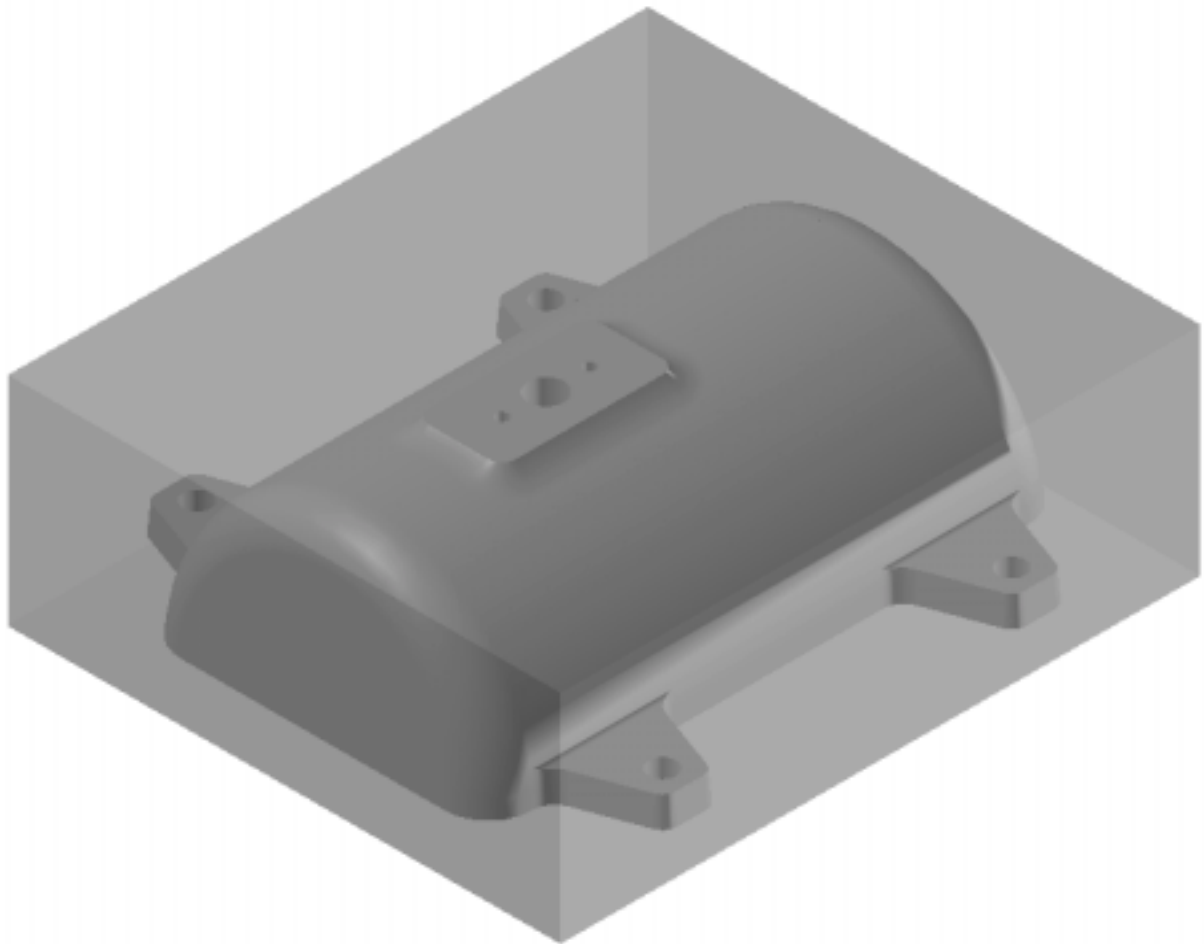

**Step 8** Create/Assign the Geometry Parent Group necessary for the Cavity Milling operation that you will be creating.

**Step 9** Create/Assign the Program Parent Group necessary for the Cavity Milling operation.

Select and/or name the Program Parent Group to aid in organizing your sequence of operations.

Use a meaningful name, such as **prog\_top\_cover\_housing**, that would be easily identifiable if you had numerous Program Parent Groups.

**Step 10** Generate a Cavity Milling tool path to rough the part.  
Use a 1.250 x .250 end mill.

**Step 11** Save and Close the assembly.





# Regeneration and Tool Path Verification

Section 3

## Unigraphics Manufacturing Process Manufacturing Operation Preparation

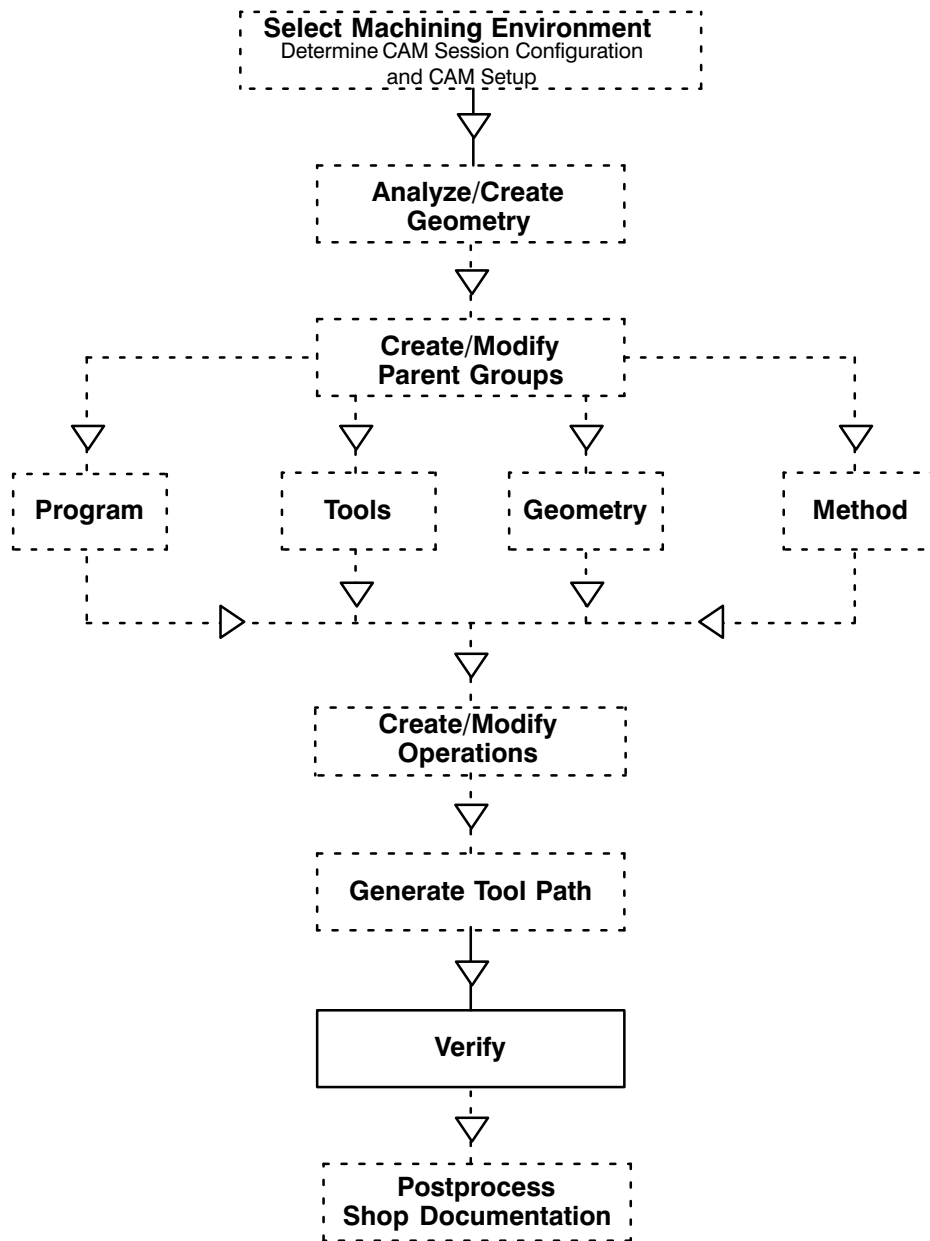

3

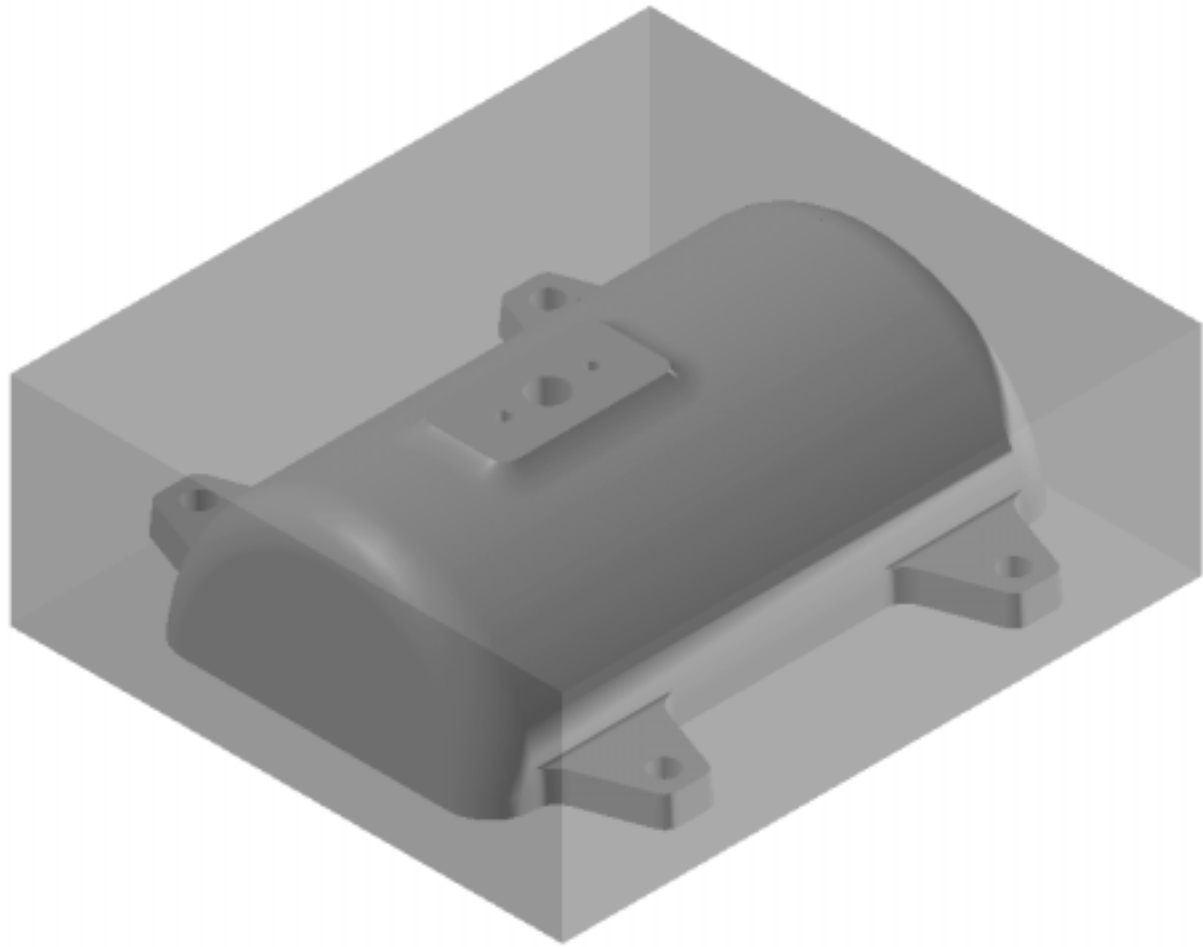

3

In this section, you will change the Tool parent group, regenerate and verify the tool paths created.

- Step 1** Open the part **\*\*\*\_explode\_cover\_mfg.prt**.
- Step 2** Change the Tool parent group in the Cavity Milling operation that you have created and regenerate the tool path (Hint: retrieve an existing end mill from the library).
- Step 3** Use the Visualization function to verify the tool paths. Verify by Replay and Dynamic Removal methods.
- Step 4** Save and close the part file.

*MCS and Smart Objects*  
Section 4

**Unigraphics Manufacturing Process**  
**Manufacturing Operation Preparation**

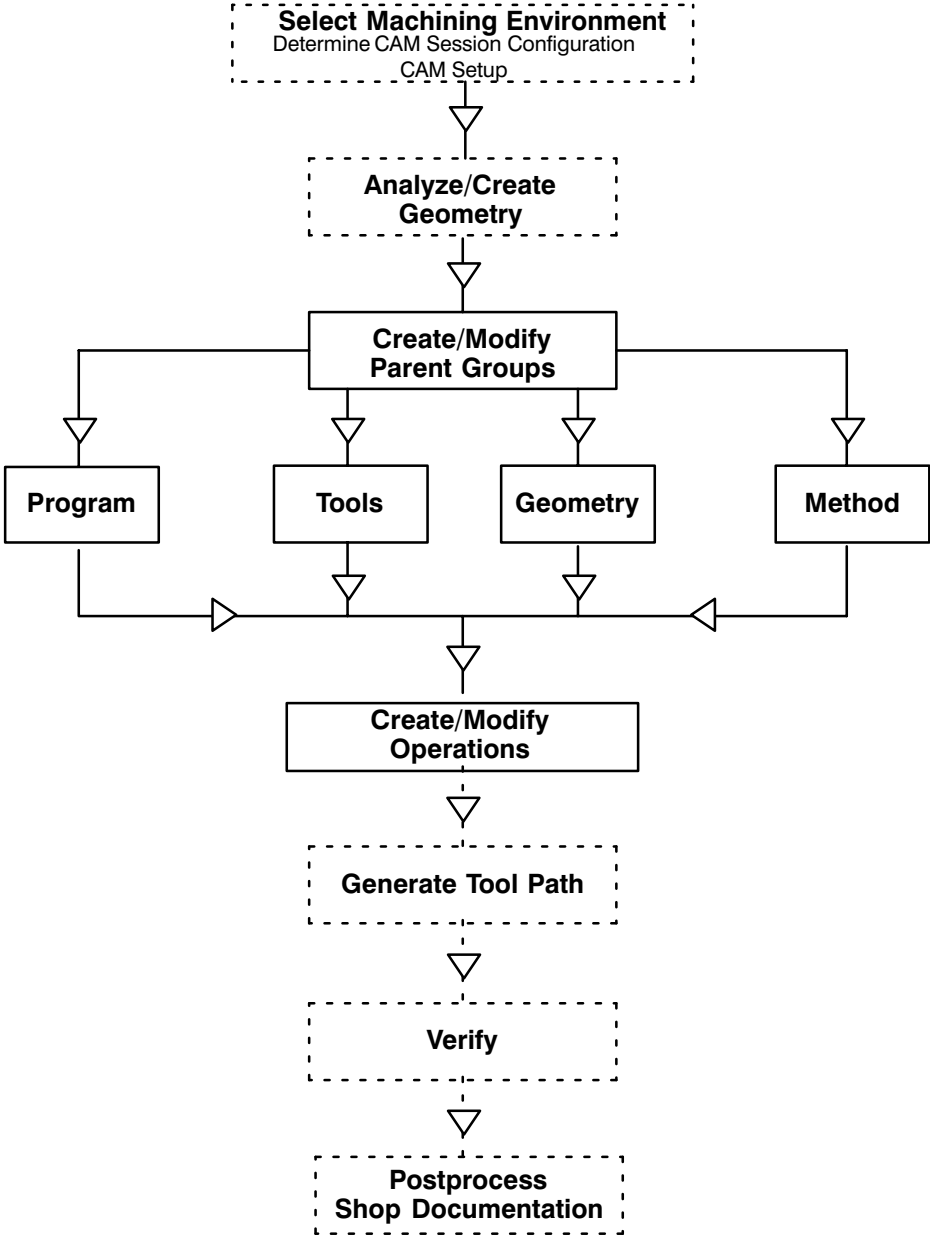

In this section, you will change the position of the MCS. You will also create a Smart Clearance Plane that you can use as avoidance geometry.

**Step 1** Open the part `***_explode_cover_mfg.prt`.

**Step 2** Edit the MCS\_MILL parent group and reposition the MCS to the center of the .625 diameter hole.

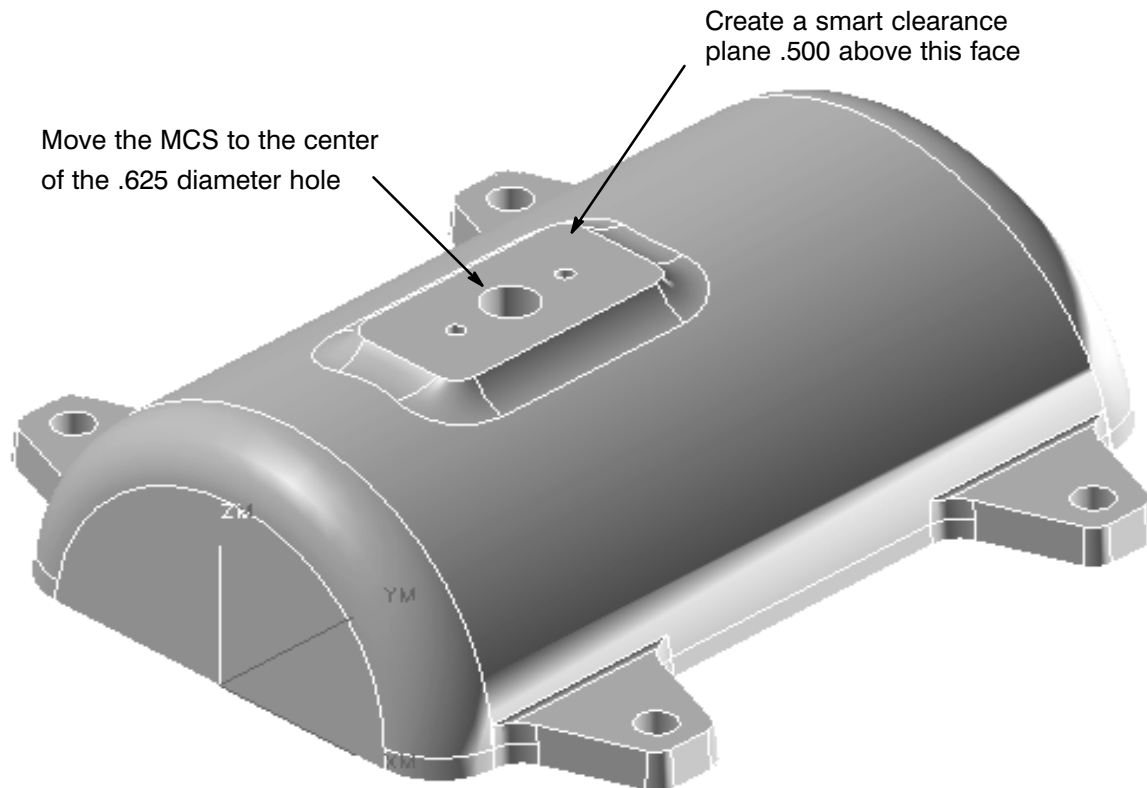

**Step 3** Create a Smart Clearance Plane .500 above the top face of the part. You can define the Clearance Plane in the MCS\_MILL parent group.

**Step 4** Use the Visualization function to verify the tool paths. Note the tool movement with respect to the Clearance Plane. Also note the output with respect to the relocated MCS.

**Step 5** Save and close the part file.



**(This Page Intentionally Left Blank)**



Face Milling  
Section 5

**Unigraphics Manufacturing Process**  
**Manufacturing Operation Preparation**

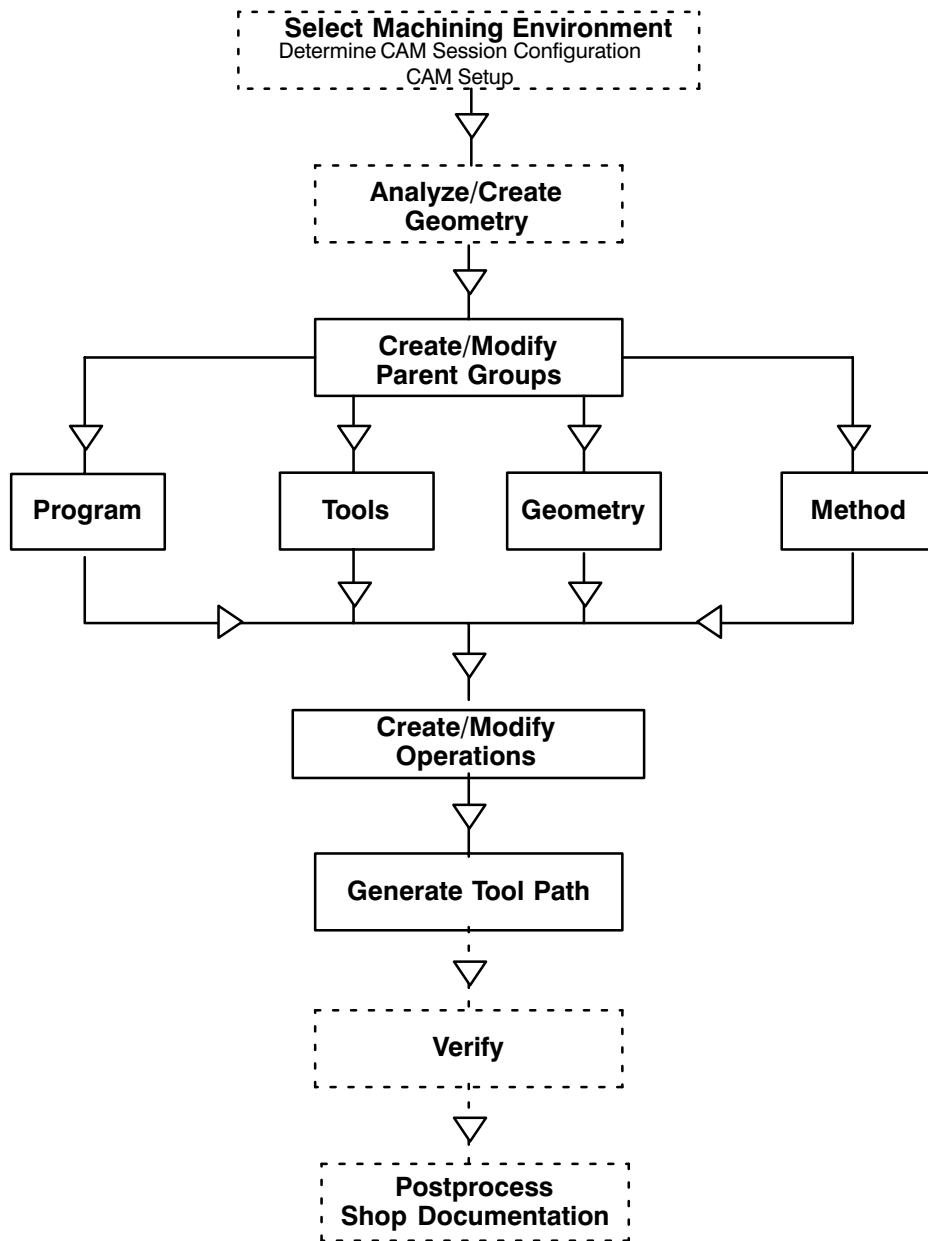

In this section of the activity, you will use the Face Milling operation types to Face Mill the top pad and the four hold down pads of the cover housing.

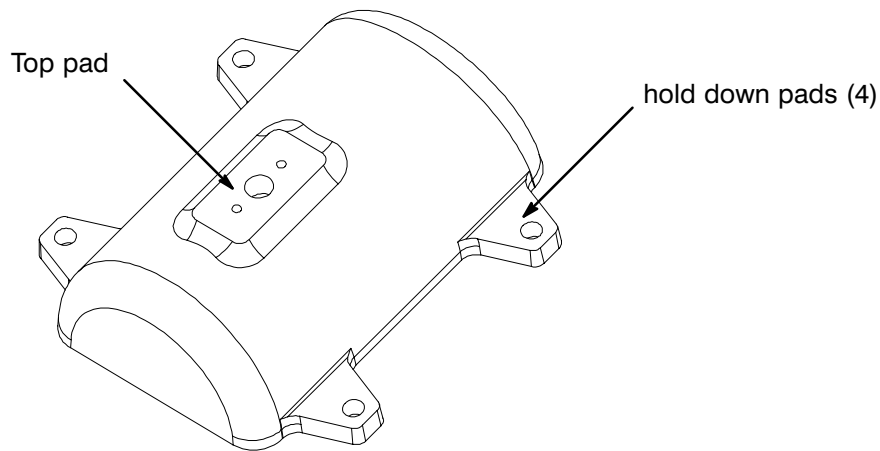

- Step 1** Open the part **\*\*\*\_explode\_cover\_mfg.prt**.
- Step 2** Create/Assign the geometry parent group necessary for the Face Milling operation that you will create.
- Step 3** Create/Assign the program parent group necessary for the Face Milling operation.
- Step 4** Create/Assign the method parent group necessary for the Face Milling operation.
- Step 5** Select the .750 diameter end mill for the Face Milling operation (operation 400.02 per the Process Planning Sheet).
- Step 6** Set the options to allow for automatic calculation of feeds and speeds.
- Step 7** Generate a Face Milling tool path to face mill the top pad and the four hold down pads.
- Step 8** Verify the tool path that you just created.
- Step 9** Save and close the part file.



*Drill Parent Groups and Operations*  
Section 6



**Unigraphics Manufacturing Process**  
**Manufacturing Operation Preparation**

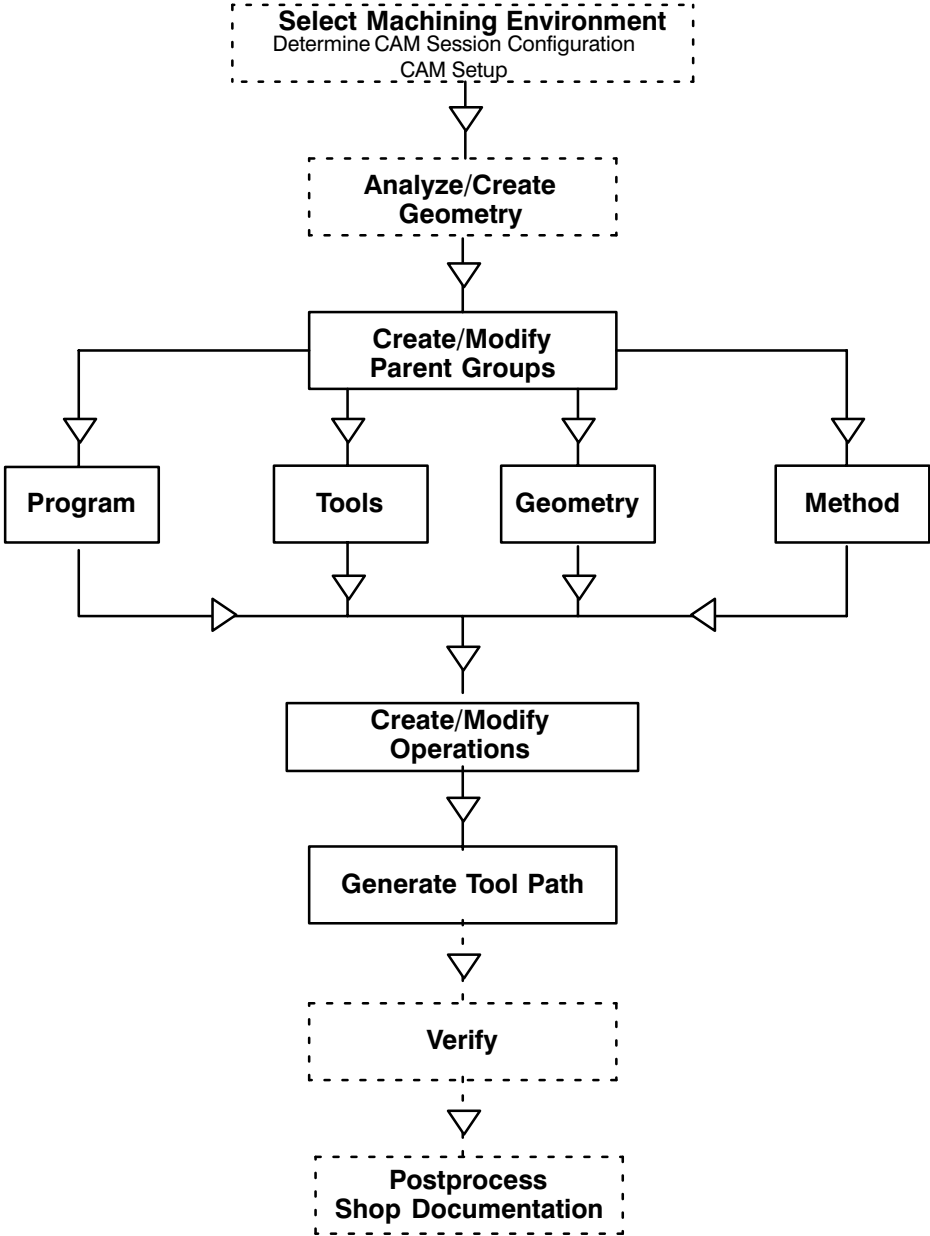

In this section of the workbook, you will create the drill geometry parent group and the drilling operations to spot drill and drill all holes.

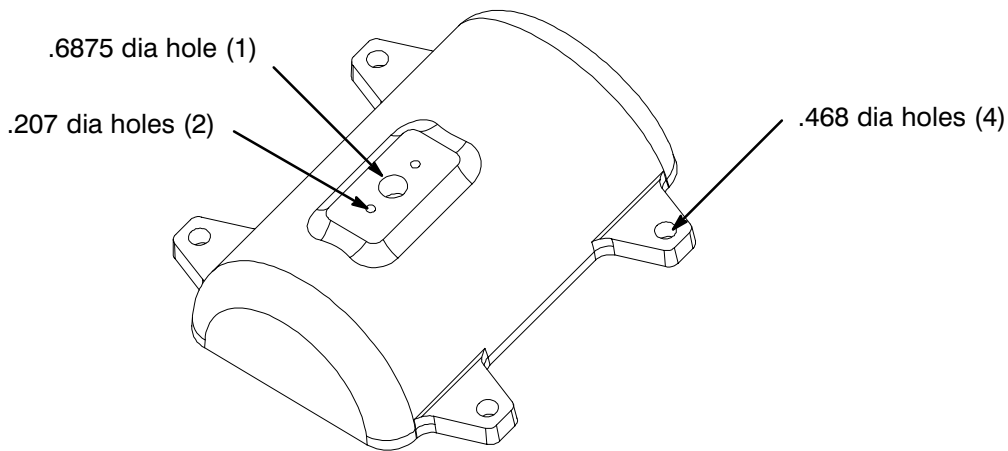

- Step 1** Open the part **\*\*\*\_explode\_cover\_mfg.prt**.
- Step 2** Create/Assign the geometry parent group necessary for the drilling operations that you will create.
- Step 3** Create/Assign the program parent group necessary for the drilling Operations.
- Step 4** Create/Assign the method Parent Group necessary for the drilling operation.
- Step 5** Center or spot drill all holes. Spot drill all holes (7). Use SPOT-.5-90-HSS spot drill.
- Step 6** Drill one .625" diameter hole. Use DR-.625-HSS drill, drill to modeled depth.
- Step 7** Drill four .468 diameter holes, drill thru. Use DR-.46875 drill.
- Step 8** Drill two .207 diameter holes, drill to modeled depth. Use DR-.207 drill.
- Step 9** Save the part file.

*Advanced Cavity Milling*  
Section 7

**Unigraphics Manufacturing Process**  
**Manufacturing Operation Preparation**

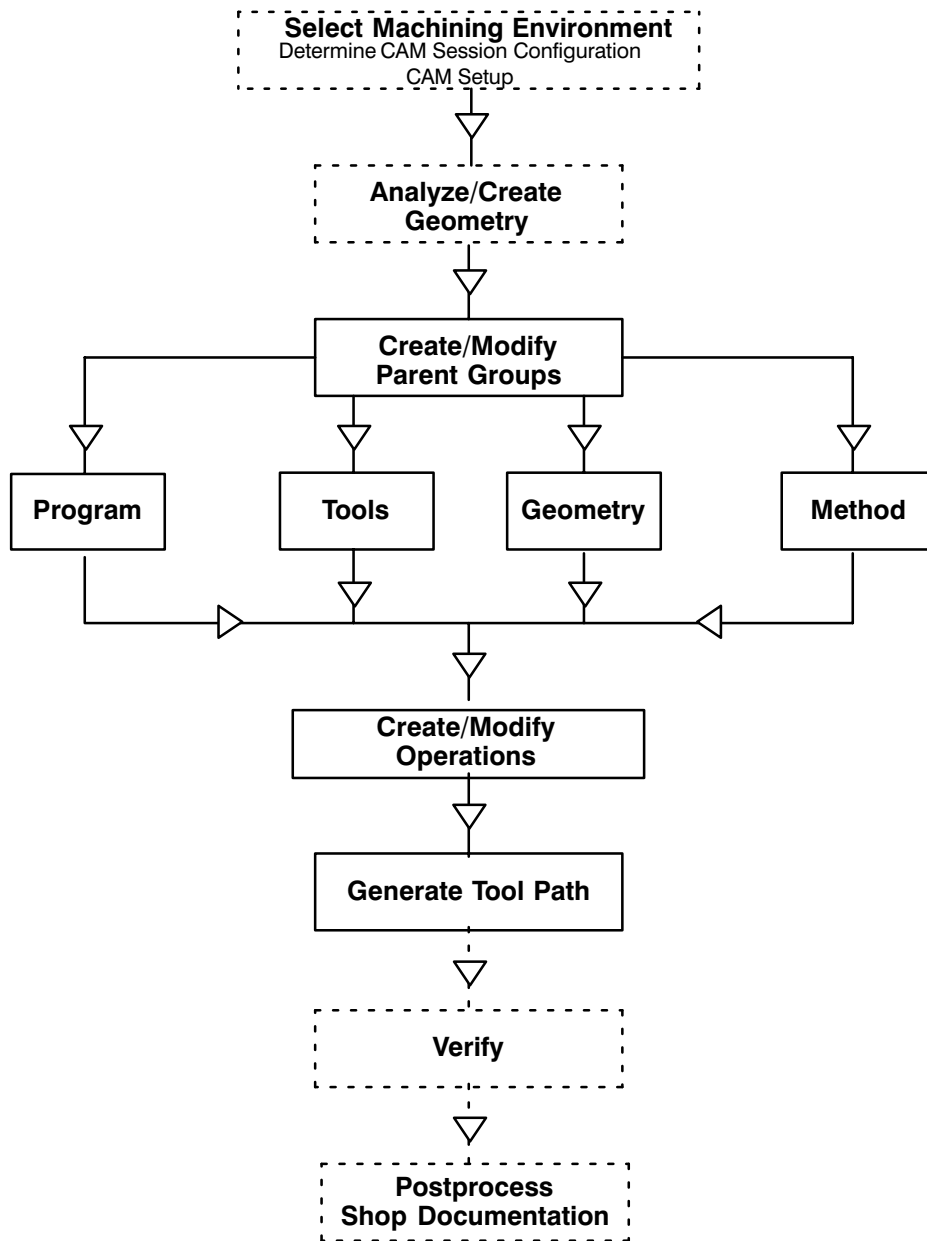

In section two of this workbook, you created a basic Cavity Milling operation to rough out the general shape of the cover from blank material. In this section of the workbook, you will create a Cavity Milling operation to remove the remaining material from one of the hold down pads. The technique recommended would be to pick one of the pads, establish a new cut range (cut level) and then generate the operation.

This procedure is out of sequence with an actual machining process, because most of the material was removed in the Face Milling operation. This part of the workbook project is design to familiarize you with additional capabilities of Cavity Milling.



**Step 1** Open the part **\*\*\*\_explode\_cover\_mfg.prt**.

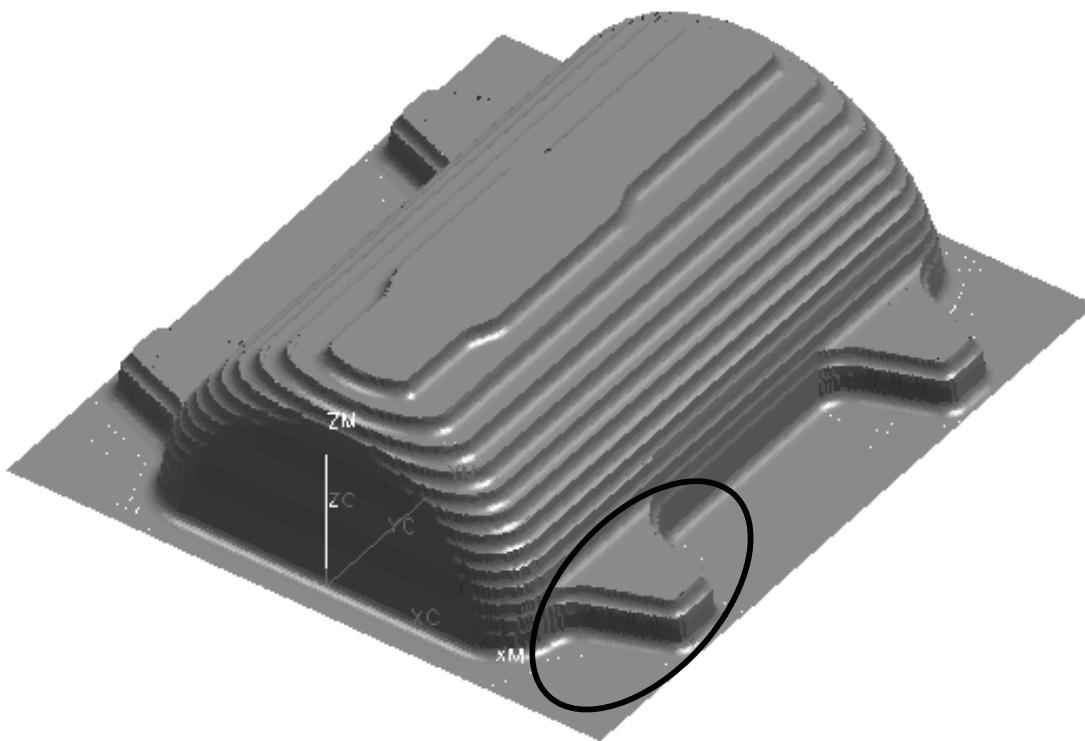

**Step 2** Modify the existing Cavity Milling operation to add a cut level at the top of the hold down pads. You will want to remove as much excess material as possible in the roughing operation.

**Step 3** Generate and verify the tool path.

**Step 4** Save and close the assembly.





**(This Page Intentionally Left Blank)**

# Planar Mill, Profile Operations

Section 8

## Unigraphics Manufacturing Process Manufacturing Operation Preparation

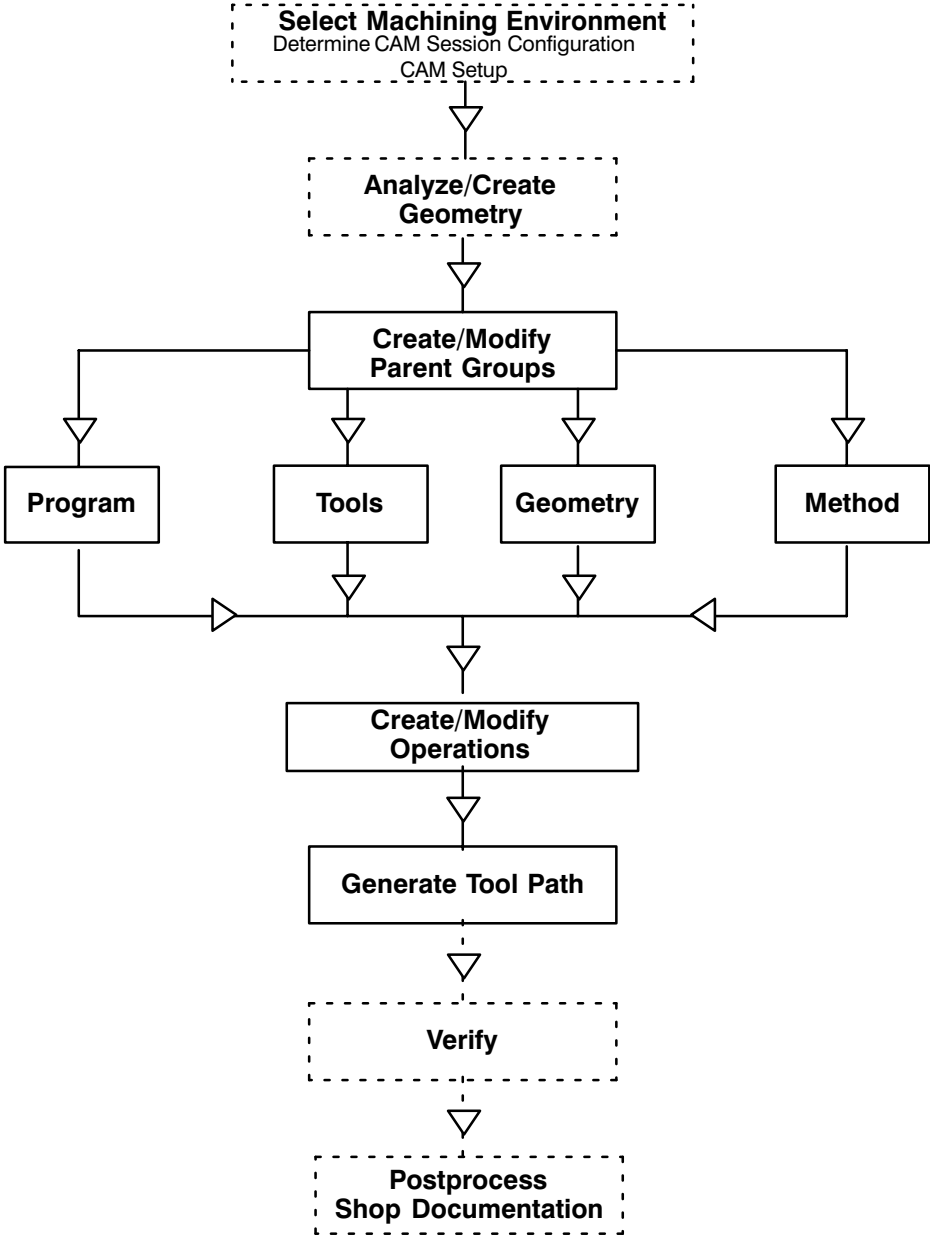

Finish all four hold down pads using a Planar Mill Profile operation.

**Step 1** Open the part `***_explode_cover_mfg.prt`.

**Step 2** Generate a Planar Mill Profile pass to finish the periphery of all the hold down pads. Use a .375 diameter end mill.

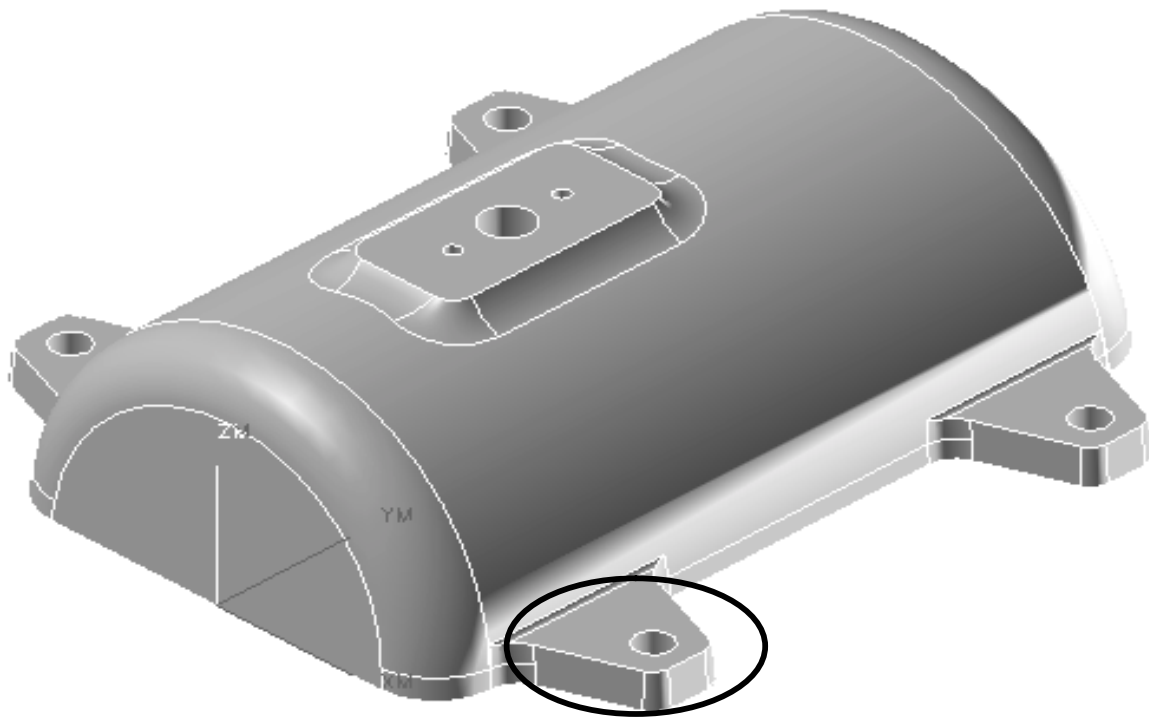

**Step 3** Verify the tool path.

**Step 4** Save and close the assembly.



# Z-Level Operations

Section 9

## Unigraphics Manufacturing Process Manufacturing Operation Preparation

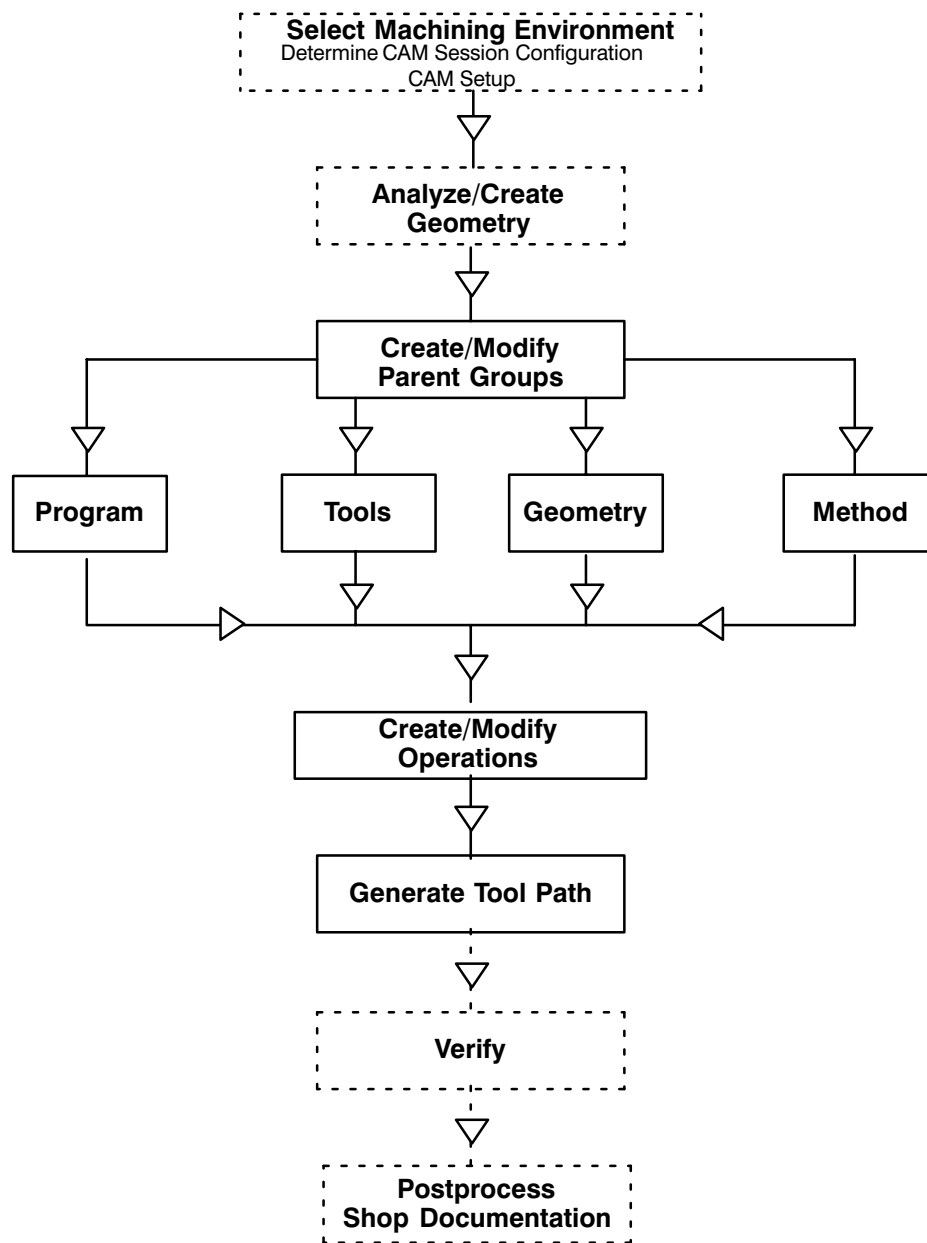

In this section of the workbook, you will create a Z-Level operation to cut all of the steep areas of the cover. You will define the geometry using a MILL\_AREA geometry parent group, generate a Z-Level Profile operation and then verify the results .

**Step 1** Open the part **\*\*\*\_explode\_cover\_mfg.prt**.

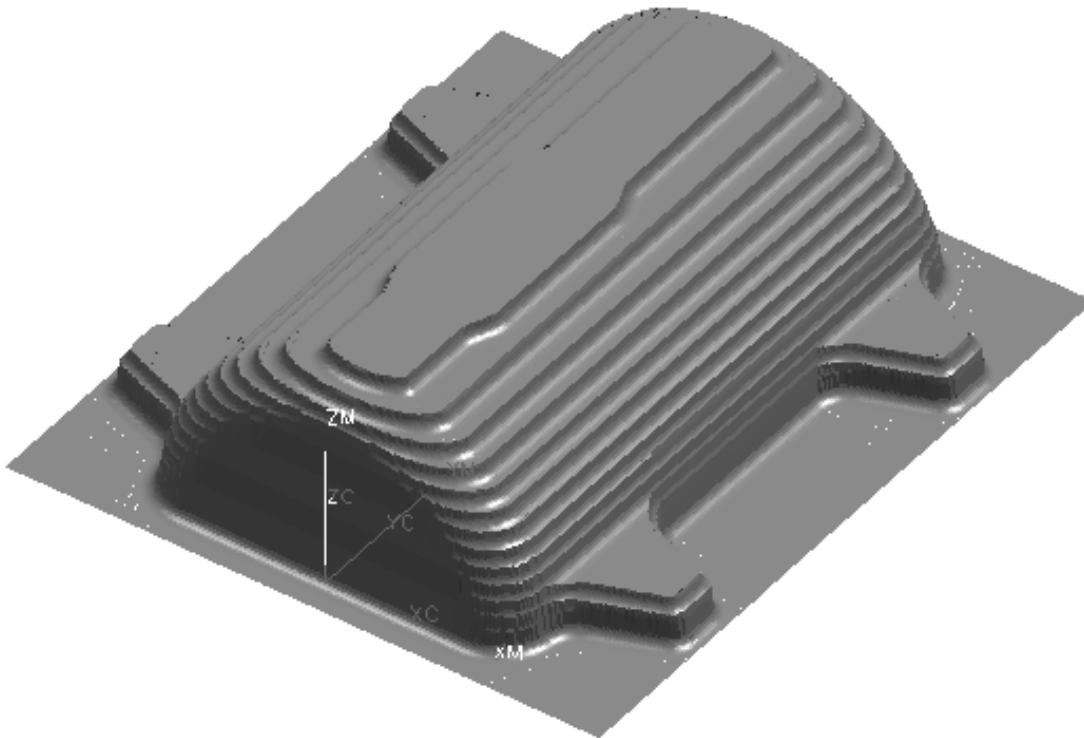

**Step 2** Create a MILL\_AREA geometry parent group that describes the area for Z-Level machining.

**Step 3** Create a Z-Level Profile operation to machine the MILL\_AREA Geometry Parent Group. Use .750 x.125 carbide end mill.

**Step 4** Verify the results.

The results should be similar to the following diagram. The lighter shades of gray represent the Z-Level Profile operation.

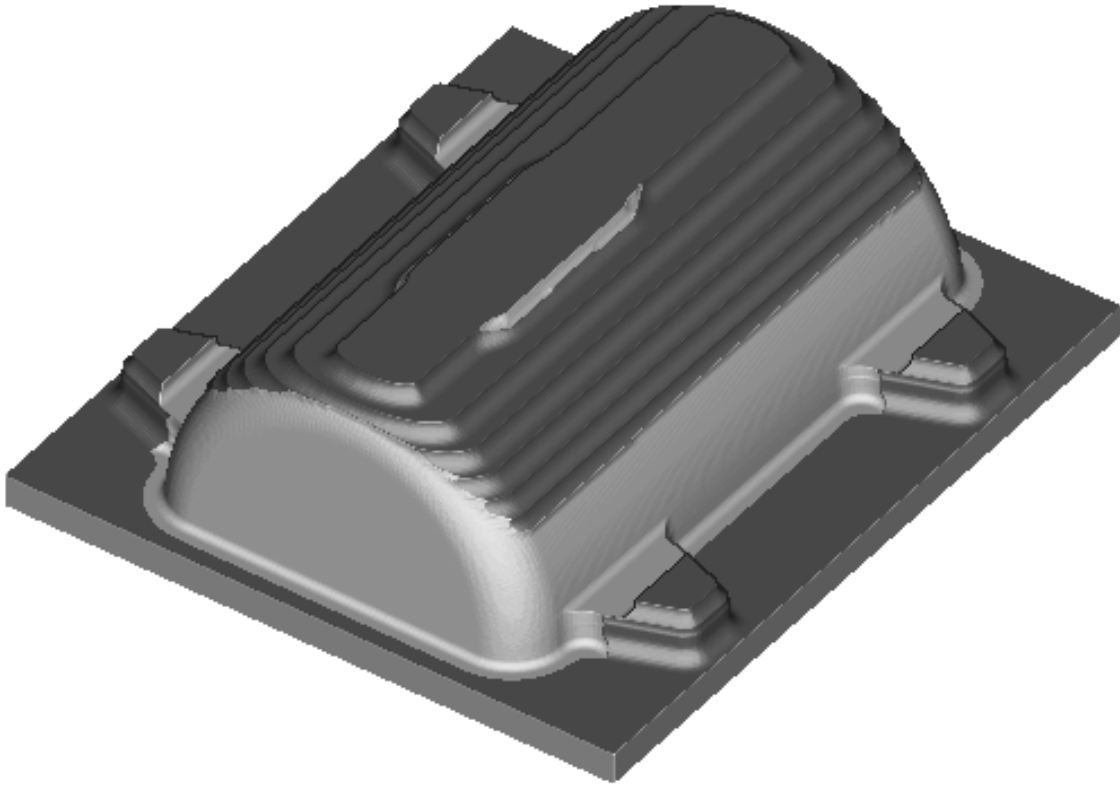
**Step 5** Save the part file.

**(This Page Intentionally Left Blank)**



*Fixed Contour Mill Area Operations*  
Section 10

**Unigraphics Manufacturing Process**  
**Manufacturing Operation Preparation**

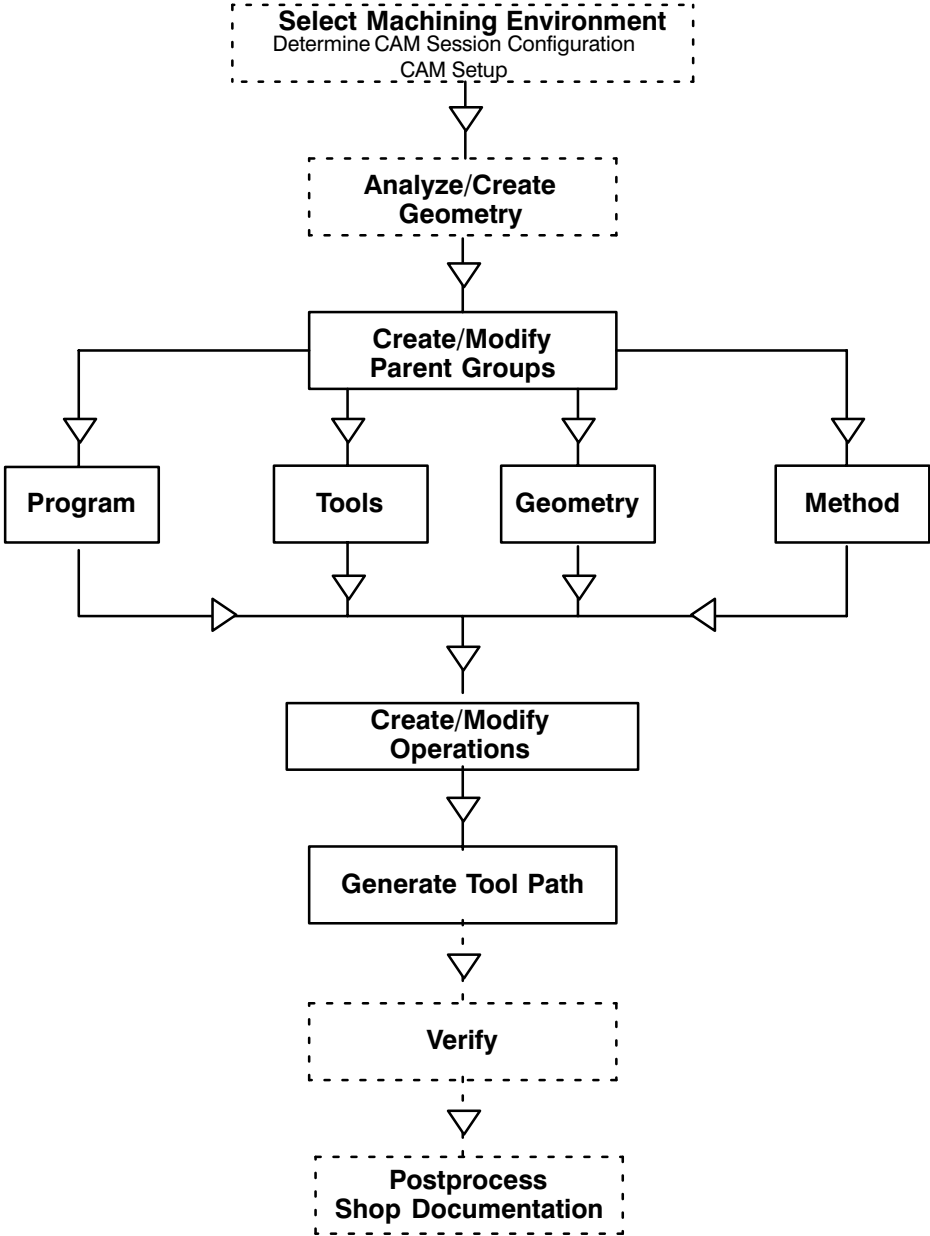

In this section of the workbook project, you will use create a MILL\_AREA geometry parent group, appropriate for a area mill drive method operation type, to finish machine the entire cover (areas not machined by Z-Level Profile).

- Step 1** Open the part **\*\*\*\_explode\_cover\_mfg.prt**.
- Step 2** Create a MILL\_AREA geometry parent group appropriate for the Area Mill Drive Method.
- Step 3** Finish mill the cover areas not finished by previous operations.

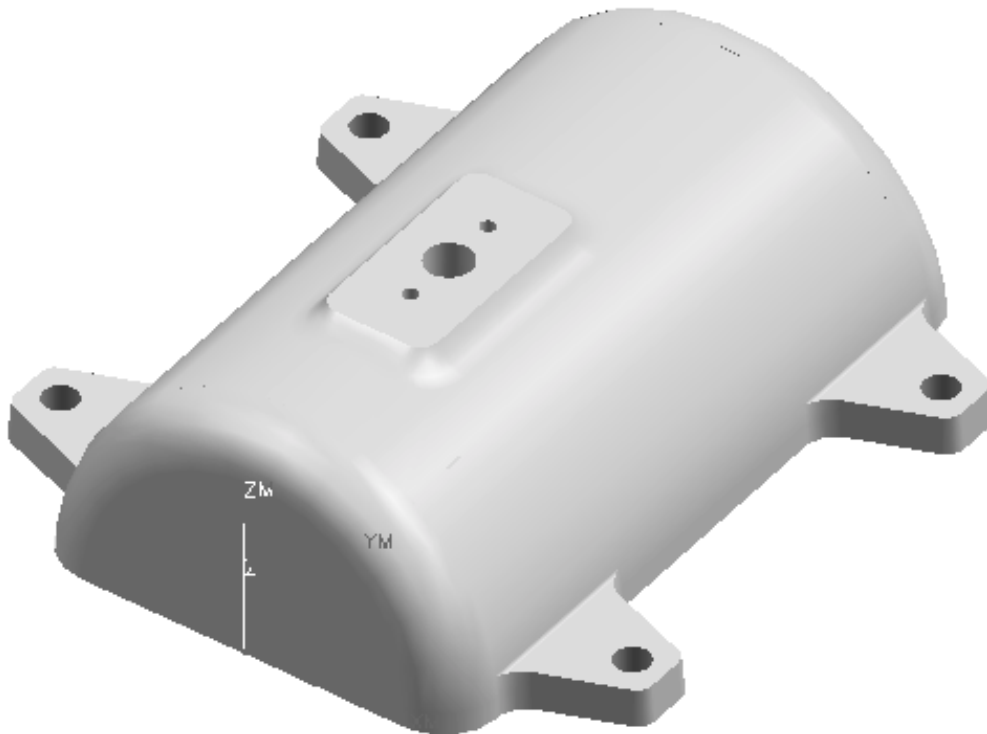

**Step 4** Verify the tool path.

Lighter area is area finished  
by Area Mill Drive Method.

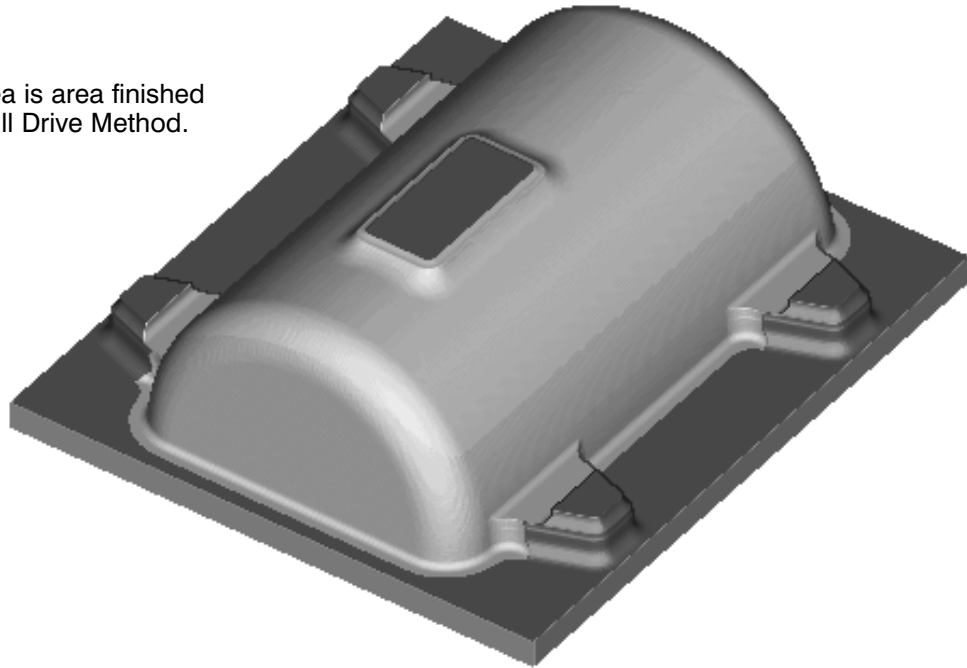

**Step 5** Save the part file.

**(This Page Intentionally Left Blank)**





*Post Processing and Shop Documentation*  
Section 11

**Unigraphics Manufacturing Process**  
**Manufacturing Operation Preparation**

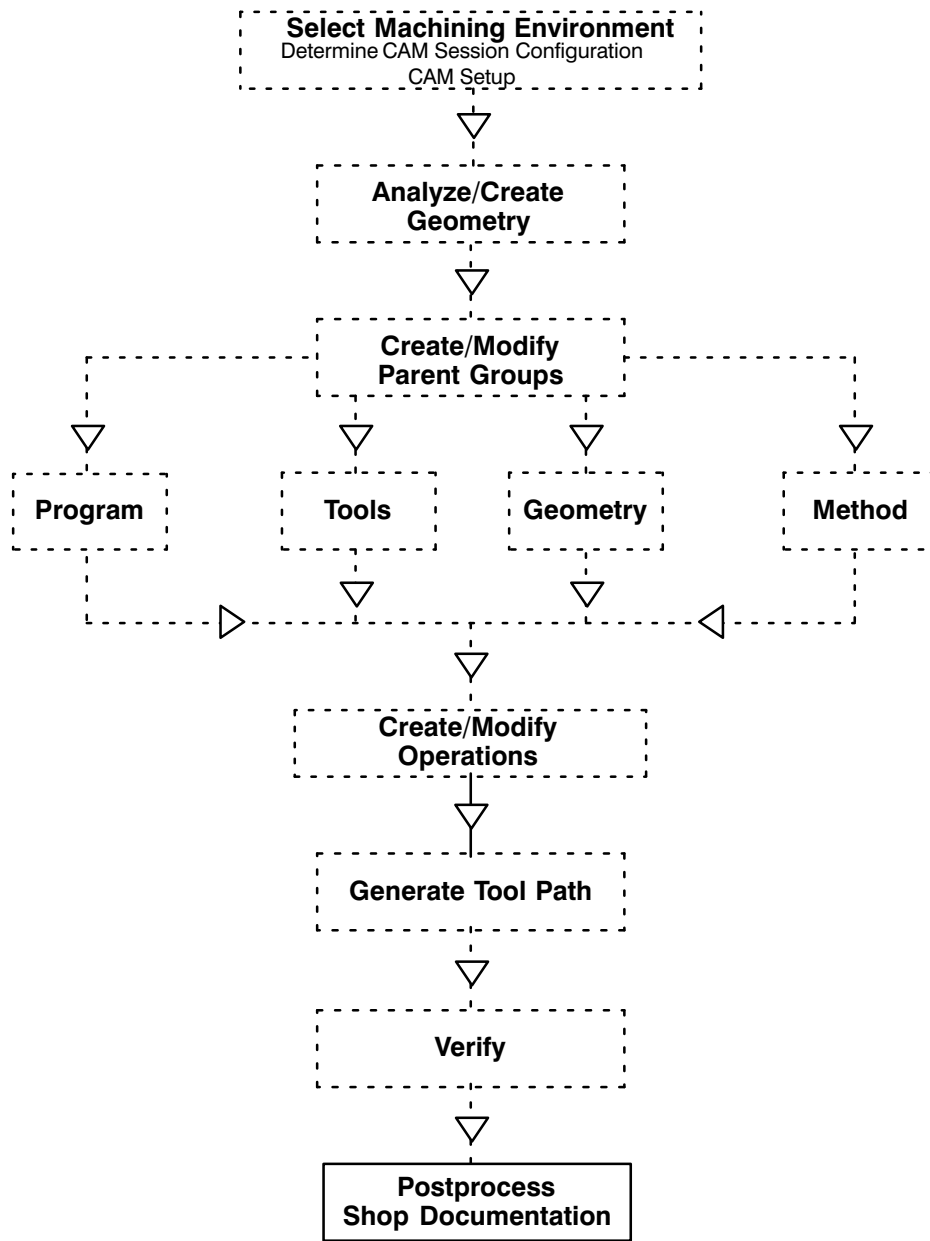

You have created operations, generated and verified tool paths and are now ready to create output for the shop.

Output will consist of Post Processed data, using UGPOST, for a particular machine tool/controller combination (you will be using MILL\_3\_AXIS as a post processor) as well as hardcopy output that is used for part set-up and processing.

**Step 1** Post process all previously generated tool paths. Use UGPOST and the post processor MILL\_3\_AXIS.

**Step 2** Create Shop Documentation output.

Create **text** based Shop Documentation with the following items:

- Tool List
- Operator List
- Operator List by Method
- Unique Tool List by Program

**Step 3** Review the Shop Documentation..

**Step 4** Create Shop Documentation output.

Create **HTML** based Shop Documentation with the following items:

- Tool List
- Operator List
- Operator List by Method
- Unique Tool List by Program
- Advanced Operator's List
- Tools and Operations

**Step 5** Review the Shop Documentation just created using a Web browser.

Shop documentation allows you to create custom information that aid in the setup and processing of data on the shop floor. You can give as little or as much information that is necessary to assist in the manufacturing operations required to machine your parts.





**(This Page Intentionally Left Blank)**



